

Model: DKL-15 X

Data

Type: Semi-hermetic piston compressors

Producer: Copeland

Series: DK

Model: DKL-15 X

Technical data

Nominal motor power [kW]:	
Cylinder count:	2
Displacement [m ³ /h]:	7,38
Cylinder capacity [cm ³]:	
RPM [min ⁻¹]:	1450
Weight [kg]:	41
Oil charge [dm ³]:	0,6
Power supply [V/~/Hz]:	

Connections

	<u>millimeters</u>	<u>inches</u>
Suction line:	15	5/8"
Discharge line:	12	1/2"

Model: DKL-15 X

Capacity

R134a

Cooling capacity [W]

$t_c \setminus t_e$	-20	-15	-10	-5	0	5	7	10	12.5
30	1 630	2 090	2 640	3 290	4 060	4 940	5 330	5 960	6 520
35	1 510	1 940	2 470	3 080	3 800	4 640	5 010	5 610	6 140
40	1 390	1 800	2 290	2 870	3 550	4 340	4 690	5 250	5 760
45	1 270	1 660	2 120	2 660	3 300	4 040	4 370	4 900	5 370
50	1 160	1 520	1 950	2 460	3 050	3 740	4 050	4 540	4 990
55	1 040	1 390	1 790	2 260	2 810	3 450	3 730	4 190	4 600
60	930	1 260	1 630	2 060	2 560	3 150	3 410	3 830	-
62	890	1 210	1 570	1 980	2 470	3 030	3 280	3 690	-

Power input [kW]

$t_c \setminus t_e$	-20	-15	-10	-5	0	5	7	10	12.5
30	0.79	0.86	0.92	0.97	1.01	1.02	1.02	1.02	1.01
35	0.82	0.90	0.98	1.05	1.11	1.14	1.15	1.16	1.16
40	0.84	0.94	1.04	1.13	1.20	1.26	1.28	1.30	1.31
45	0.87	0.98	1.09	1.20	1.29	1.36	1.39	1.43	1.45
50	0.89	1.01	1.14	1.26	1.37	1.46	1.50	1.55	1.58
55	0.91	1.04	1.18	1.32	1.44	1.56	1.60	1.66	1.70
60	0.92	1.07	1.22	1.36	1.51	1.64	1.69	1.76	-
62	0.93	1.08	1.23	1.38	1.53	1.67	1.72	1.80	-

Operating conditions: suction gas temperature 25°C + additional cooling

t_c - Condensing temperature [°C]

t_e - Evaporating temperature [°C]

Model: DKL-15 X

Capacity

R404A/R507

Cooling capacity [W]

$t_c \setminus t_e$	-50	-45	-40	-35	-30	-25	-20
20	740	1 030	1 390	1 820	2 330	2 930	3 630
25	650	930	1 270	1 680	2 160	2 730	3 400
30	570	830	1 150	1 540	1 990	2 530	3 160
35	480	730	1 030	1 390	1 820	2 320	2 910
40	400	630	910	1 250	1 650	2 120	2 670
45	320	540	790	1 100	1 470	1 910	2 420
50	-	440	680	960	1 300	1 700	2 170
55	-	340	560	820	1 120	1 490	-

Power input [kW]

$t_c \setminus t_e$	-50	-45	-40	-35	-30	-25	-20
20	0.74	0.82	0.90	0.97	1.04	1.10	1.14
25	0.73	0.82	0.91	0.99	1.08	1.16	1.23
30	0.71	0.81	0.91	1.01	1.12	1.22	1.31
35	0.68	0.79	0.91	1.03	1.15	1.27	1.39
40	0.64	0.77	0.90	1.04	1.18	1.32	1.46
45	0.60	0.74	0.89	1.04	1.20	1.36	1.53
50	-	0.70	0.87	1.04	1.22	1.40	1.59
55	-	0.66	0.84	1.03	1.23	1.44	-

Operating conditions: suction gas temperature 25°C + additional cooling

t_c - Condensing temperature [°C]

t_e - Evaporating temperature [°C]

Model: DKL-15 X

Dimensions

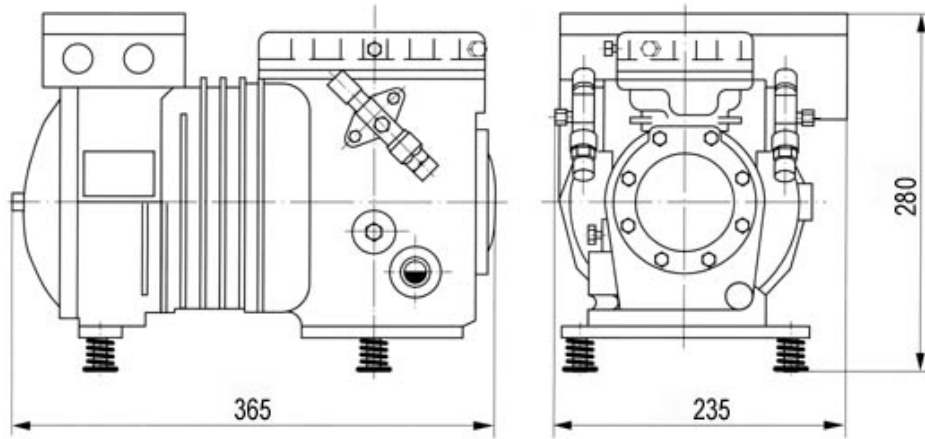

Model: DKL-15 X

Image

